

320KHz, 2A Asynchronous Buck Regulator



General Description

The FP6111 is a wide input range buck switching regulator suitable for most applications. The FP6111 includes a high current P-MOSFET, a high precision reference (0.8V) for comparing output voltage with a feedback amplifier, an internal soft start timer and dead-time controller. The oscillator controls both the maximum duty cycle and PWM frequency.

Features

- Precision Feedback Reference Voltage: 0.8V (2%)
- Wide Supply Voltage Operating Range: 3.6 to 20V
- Low Current Consumption: 3mA
- Internal Fixed Oscillator Frequency: 320KHz (Typ.)
- Internal Soft-Start Function (SS)
- Built-In P-MOSFET for 2A Output Loading
- Over Current Protection
- Package: SOP-8L

Typical Application Circuit

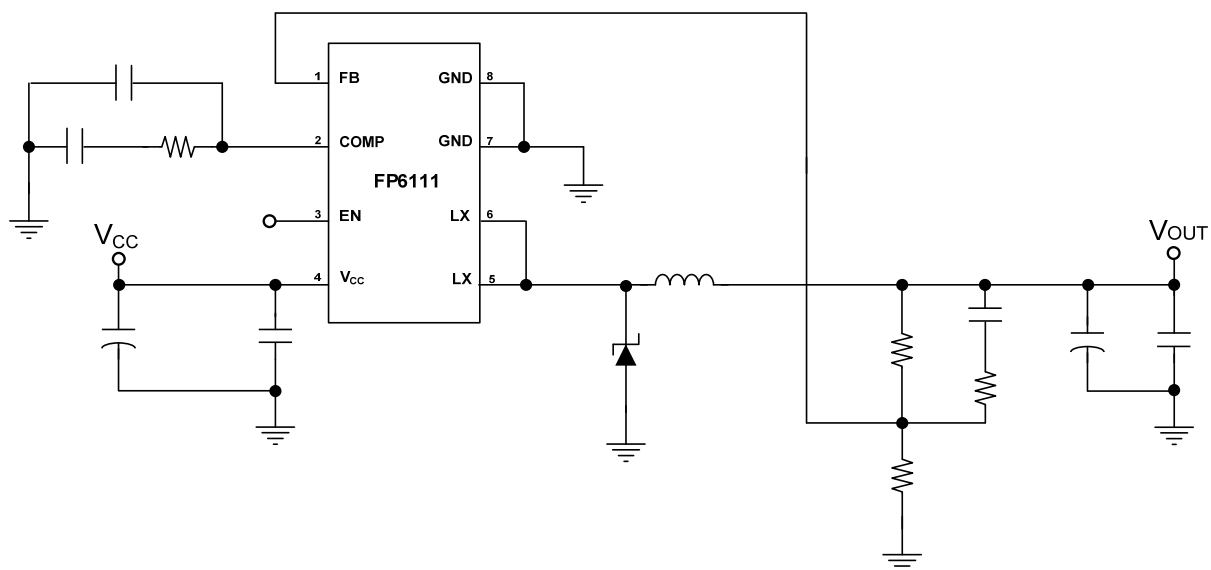

Function Block Diagram

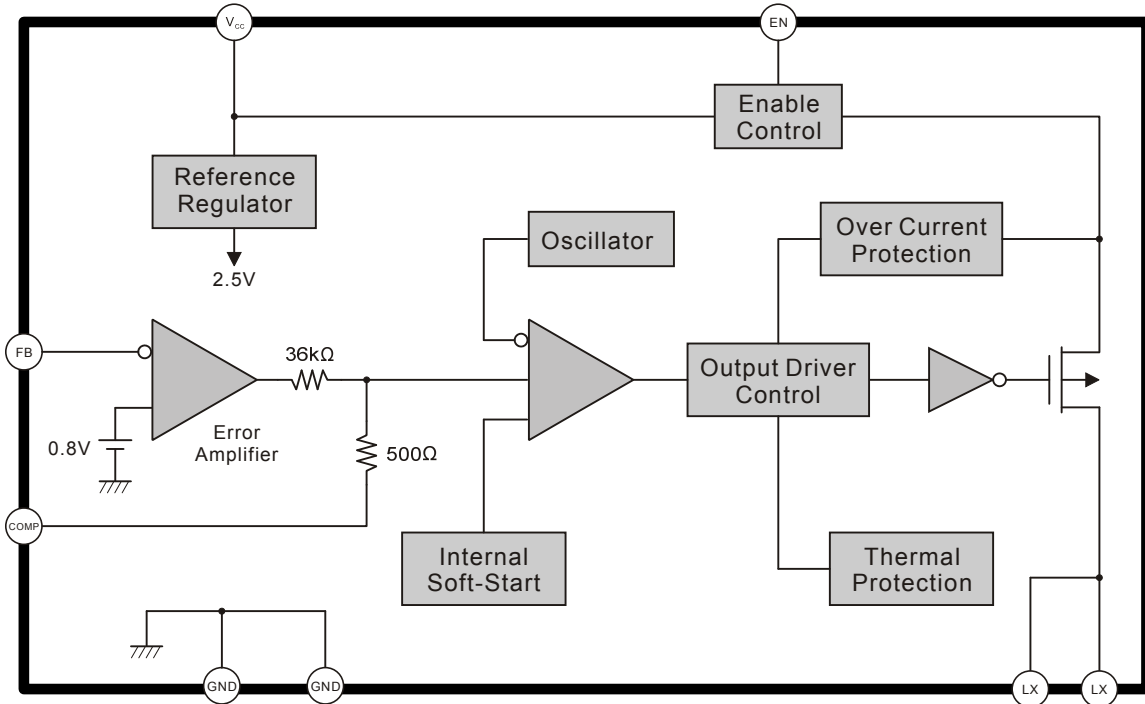

Pin Descriptions

SOP-8L

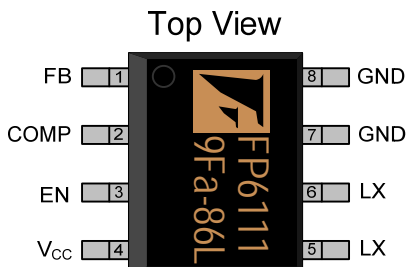

Name	No.	I / O	Description
FB	1	I	Error Amplifier Inverting Input
COMP	2	O	Error Amplifier Output for Compensation
EN	3	I	Enable Control
V _{CC}	4	P	IC Power Supply (PMOS Source)
LX	5	O	PMOS High Current Output
LX	6	O	PMOS High Current Output
GND	7	P	IC Ground
GND	8	P	IC Ground

This datasheet contains new product information. Feeling Technology reserves the rights to modify the product specification without notice. No liability is assumed as a result of the use of this product. No rights under any patent accompany the sales of the product.

IC Date Code Identification

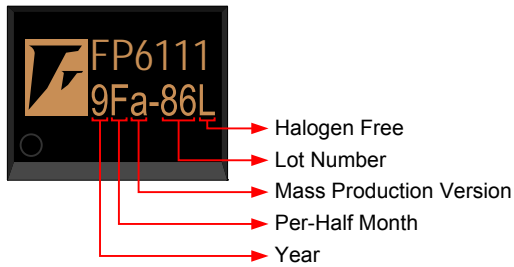

Halogen Free: Halogen free product indicator

Lot Number: Wafer lot number's last two digits

For Example: 1323~~86~~TB → 86

Mass Production Version: Mass production mask version

Per-Half Month: Production period indicated in half month time unit

For Example: January → A (Front Half Month), B (Last Half Month)

February → C (Front Half Month), D (Last Half Month)

Year: Production year's last digit

Ordering Information

Part Number	Operating Temperature	Package	MOQ	Description
FP6111D-G1	-25°C ~ +85°C	SOP-8L	100 EA	Tube
FP6111DR-G1	-25°C ~ +85°C	SOP-8L	2500 EA	Tape & Reel

Absolute Maximum Ratings

Parameter	Symbol	Conditions	Min.	Typ.	Max.	Unit
Power Supply Voltage	V_{CC}				25	V
Output Source Current					2.2	A
Error Amplifier Inverting Input			-0.3		1.2	V
Allowable Power Dissipation	P_D	SOP-8L $T_A \leq +25^\circ\text{C}$			650	mW
Junction to Ambient Thermal Resistance	θ_{JA}				+175	$^\circ\text{C} / \text{W}$
Junction to Case Thermal Resistance	θ_{JC}				+45	$^\circ\text{C} / \text{W}$
Operating Temperature			-25		+85	$^\circ\text{C}$
ESD Susceptibility		HBM (Human Body Mode)	2			KV
		MM (Machine Mode)	200			V
Storage Temperature	T_S	SOP-8L	-55		+125	$^\circ\text{C}$
SOP-8L Lead Temperature		(soldering, 10 sec)			+260	$^\circ\text{C}$

Suggested IR Re-flow Soldering Curve

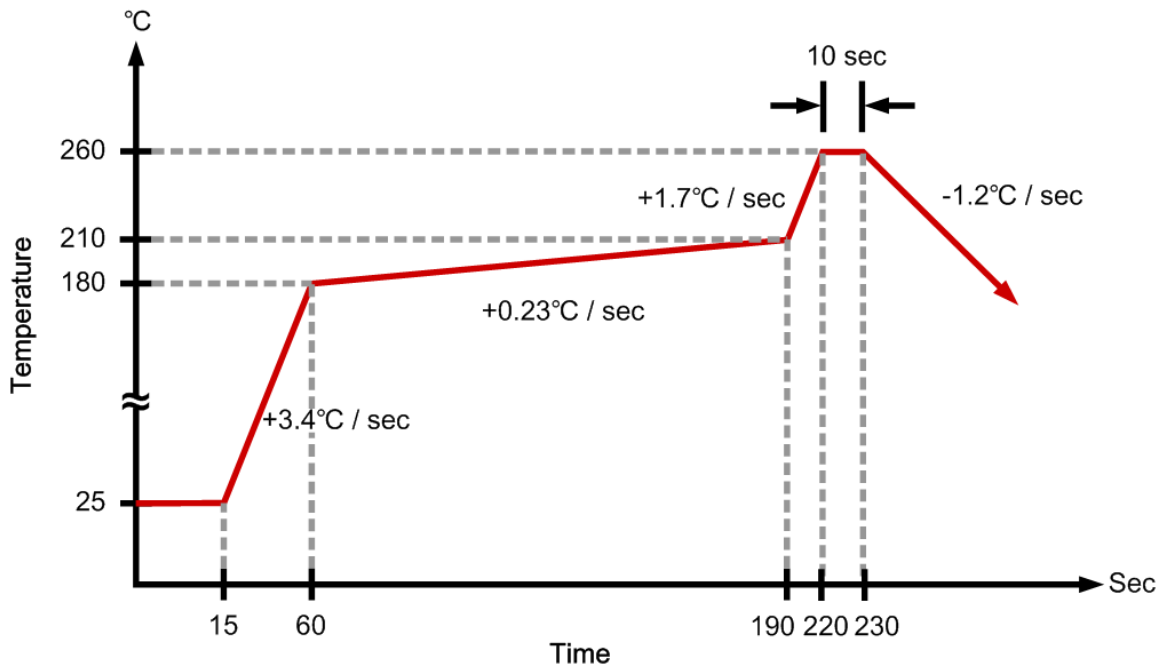

This datasheet contains new product information. Feeling Technology reserves the rights to modify the product specification without notice. No liability is assumed as a result of the use of this product. No rights under any patent accompany the sales of the product.

Recommended Operating Conditions

Parameter	Symbol	Conditions	Min.	Typ.	Max.	Unit
Supply Voltage	V_{CC}		3.6		20	V
Operating Temperature			-25		85	°C

DC Electrical Characteristics ($V_{CC}=6V$, $T_A = 25^\circ C$, unless otherwise noted)

Parameter	Symbol	Conditions	Min.	Typ.	Max.	Unit
Reference						
Feedback Voltage	V_{REF}		0.784	0.8	0.816	V
Input Regulation	$\frac{\Delta V_{REF}}{V_{REF}}$	$V_{CC}=3.6$ to 20 V		2	12.5	mV
Feedback Voltage Change with Temperature	$\frac{\Delta V_{REF}}{V_{REF}}$	$T_A = -25$ to $+25^\circ C$		1	2	%
		$T_A = 25$ to $+85^\circ C$		1	2	%
Oscillator Section						
Oscillation Frequency	f	$0.4V < V_{COMP} < 0.7V$		320		KHz
Short Circuit or Over Current Oscillation Frequency	f_{SC}	$V_{COMP} < 0.4V$		30		KHz
Frequency Change with Voltage	$\Delta f / \Delta V$	$V_{CC}=3.6V$ to $25V$		5		%
Frequency Change with Temperature	$\Delta f / \Delta T$	$T_A = -25$ to $+85^\circ C$		5		%
Idle Period Adjustment Section						
Maximum Duty Cycle	T_{DUTY}	$V_{FB} = 0.2V$		80		%
Output Section						
PMOS source Current	I_D		-2			A
PMOS D-S Voltage	V_{DSS}	$V_{COMP}=0.1V$	-30			V
Output Leakage Current	I_L			5		μA
PMOS On Resistance	$R_{DS(ON)}$	$V_{CC}=5.0V$, $V_{FB}=0V$		70	150	m Ω
		$V_{CC}=10V$, $V_{FB}=0V$		42	90	m Ω
Thermal Shutdown Section						
Thermal Shutdown Temperature				+150		°C
Over Current Protection Section						
PMOS OCP Current	I_{OCP}	$V_{CC}=12V$		4		A
Total Device Section						
EN Pin Input Current	I_{EN}	$V_{EN} = GND$			20	μA
EN Pin On Threshold	V_{UPPER}	EN pin upper		1.12		V
EN Pin Off Threshold	V_{LOW}	EN pin low		0.87		V
EN Pin Hysteresis	V_{HYS}		210	250		mV
Supply Shutdown Current	I_{SD}	$V_{EN}=0V$		2	10	μA
Supply Average current	I_{AVE}			4	6	mA

This datasheet contains new product information. Feeling Technology reserves the rights to modify the product specification without notice. No liability is assumed as a result of the use of this product. No rights under any patent accompany the sales of the product.

Parameter	Symbol	Conditions	Min.	Typ.	Max.	Unit
Error Amplifier Section						
Input Bias Current	I_B				-1.0	μA
Voltage Gain	A_V			100		V / V
Frequency Bandwidth	BW	$A_V=0$ dB		6		MHz
Output Voltage Swing Positive	V_{POS}		1.7	2		V
Output Voltage Swing Negative	V_{NEG}			0.1	0.2	V
Output Source Current	I_{SOURCE}	$V_{COMP}=800\text{mV}$	-15	-30		μA
Output Sink Current	I_{SINK}	$V_{COMP}=800\text{mV}$	15	30		μA

This datasheet contains new product information. Feeling Technology reserves the rights to modify the product specification without notice. No liability is assumed as a result of the use of this product. No rights under any patent accompany the sales of the product.

Typical Operating Characteristics

($V_{IN}=12V$, $V_{OUT}=3.3V$, $I_{OUT}=2A$, $T_A=25^\circ C$, unless otherwise noted)

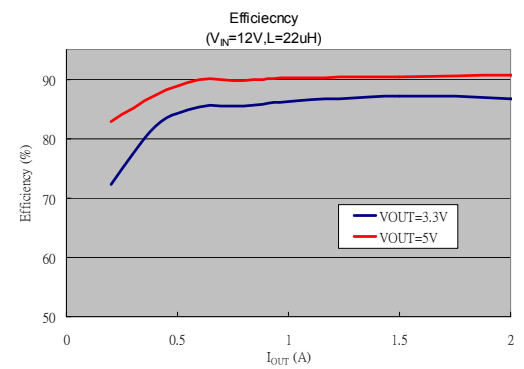
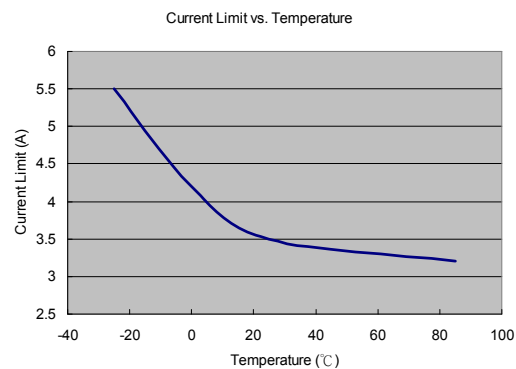
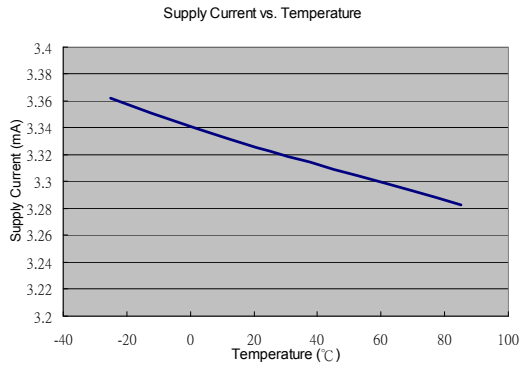
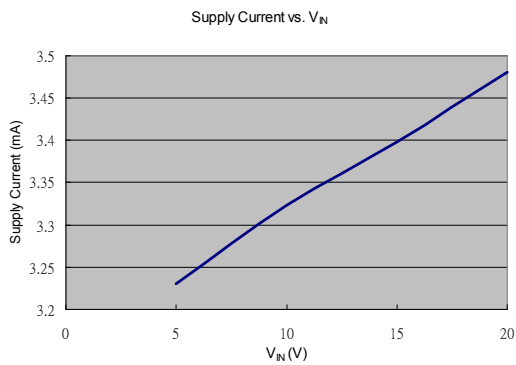
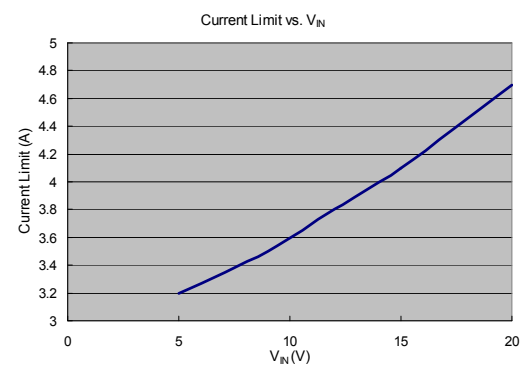
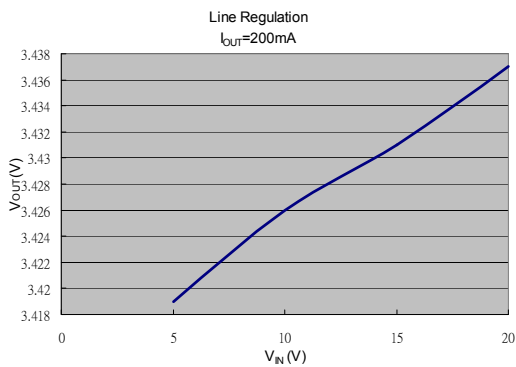
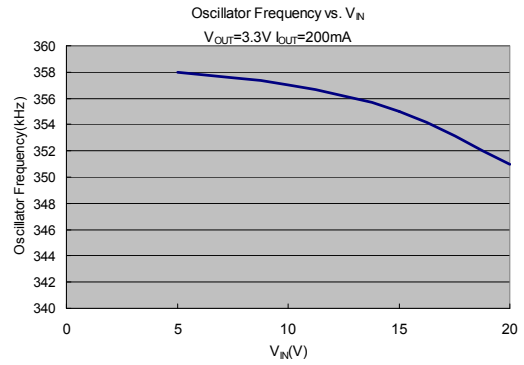
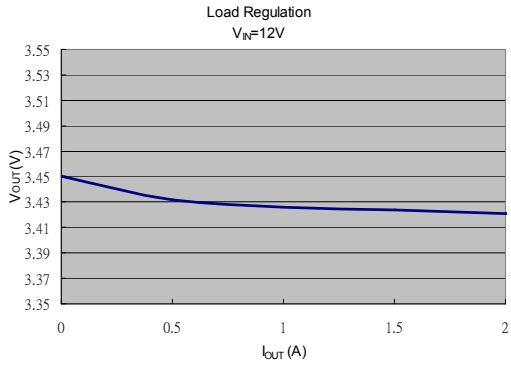

This datasheet contains new product information. Feeling Technology reserves the rights to modify the product specification without notice. No liability is assumed as a result of the use of this product. No rights under any patent accompany the sales of the product.

Output Ripple

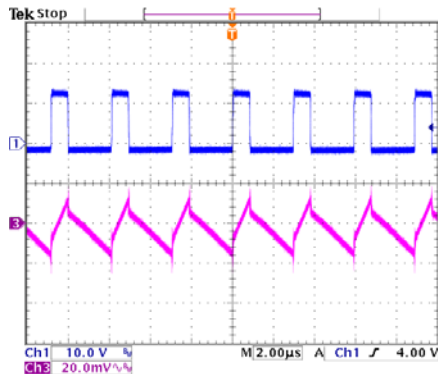

Ch1: LX, Ch2: V_{OUT}

Transient Response

(I_{OUT}=0.1A to 2A)

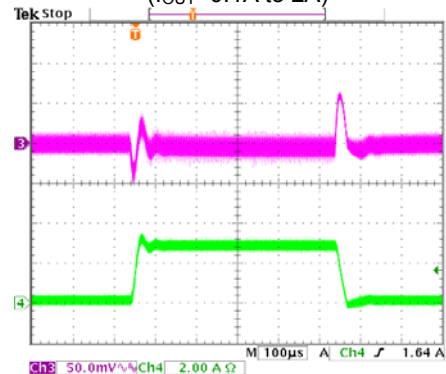

Ch3: V_{OUT}, Ch4: I_{LX}

EN on Test

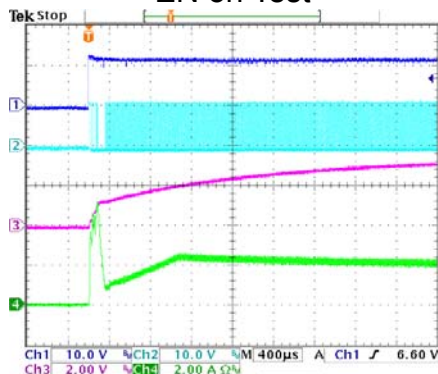

Ch1: EN, Ch2: LX, Ch3: V_{OUT}, Ch4: I_{LX}

Power on Test

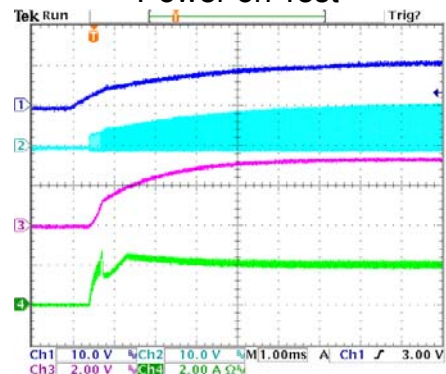

Ch1: V_{IN}, Ch2: LX, Ch3: V_{OUT}, Ch4: I_{LX}

Function Description

Voltage Reference

A 2.5V reference regulator supplies FP6111 internal circuits and uses a resistive divider to provide 0.8V precision reference voltage on the non-inverting terminal of error amplifier.

Error Amplifier

The error amplifier compares a sample of the DC-DC converter output voltage to the 0.8V (V_{REF}) reference and generates an error signal for the PWM comparator. Output voltage of the DC-DC converter is setting by the resistor divider with following expression (see Figure 1)

$$V_{OUT} = \left(1 + \frac{R_2}{R_1}\right) \times V_{REF}$$

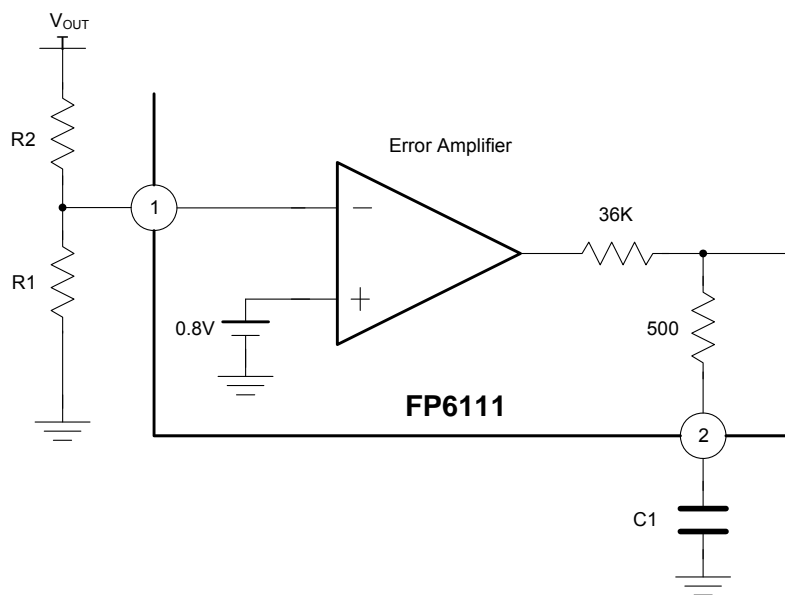

Figure 1 Error Amplifier with Feedback resistance divider

The recommended resistor value is summarized below:

V_{OUT} (V)	R_1 (k Ω)	R_2 (k Ω)
1.8	2.4k	3k
2.5	3.2k	6.8k
3.3	1.5k	4.7k
5	2k	10.5k

Oscillator

The fixed frequency is generated by an internal RC oscillator. Its typical value is 320KHz in normal operation and 30KHz in short circuit condition.

Thermal Protection

When a heavy loading draws current from the regulator, the chip temperature will rise. Once the junction temperature exceeds 150°C, FP6111 thermal protection function will be triggered and the LX output will be turned off. When junction temperature is lower, FP6111 starts again and enable LX pin output.

Over Current Protection

The FP6111 uses cycle-by-cycle current limit to protect the internal power switch. During each switching cycle, a current limit comparator detects if the power switch current exceeds the internal setting current. Once over current occurs, the oscillator frequency will decrease to prevent the driver from burning out.

Application Information

Input Capacitor Selection

The input capacitor must be connected between the V_{CC} and GND pin of the FP6111 to maintain steady input voltage and filter out the pulsing input current. The voltage rating of input capacitor must be greater than maximum input voltage plus ripple voltage.

In switch mode, the input current is discontinuous in a buck converter. The source current of the high-side MOSFET is a square wave. To prevent large voltage transients, a low ESR input capacitor sized for the maximum RMS current must be used. The RMS value of input capacitor current can be calculated by:

$$I_{RMS} = I_{O_MAX} \sqrt{\frac{V_O}{V_{IN}} \left(1 - \frac{V_O}{V_{IN}}\right)}$$

It can be seen that when V_O is half of V_{IN} , C_{IN} is under the worst current stress. The worst current stress on C_{IN} is $I_{O_MAX} / 2$.

Inductor Selection

The value of the inductor is selected based on the maximum tolerant ripple current. Large inductance gives low inductor ripple current and small inductance result in high ripple current. However, the larger value inductor usually has a larger physical size, higher series resistance, and lower saturation current. On the experience, the value is to allow the peak-to-peak ripple current in the inductor to be 10%~20% maximum load current. The inductance value can be calculated by:

$$L = \frac{(V_{IN} - V_O) V_O}{f \times \Delta I_L} = \frac{(V_{IN} - V_O) V_O}{f \times [2 \times (10\% \sim 20\%) I_O]}$$

The inductor ripple current can be calculated by:

$$\Delta I_L = \frac{V_O}{f \times L} \times \left(1 - \frac{V_O}{V_{IN}}\right)$$

Choose an inductor that does not saturate under the worst-case load conditions, which is the load current plus half the peak-to-peak inductor ripple current even at the highest operating temperature. The peak inductor current is:

$$I_{L_PEAK} = I_O + \frac{\Delta I_L}{2}$$

The inductors in different shape and style are available from manufacturers. Shielded inductors are small and radiate less EMI issue. But they cost more than unshielded inductors. The choice depends on EMI requirement, price and size.

Inductor Value (μH)	Dimensions(mm)	Component Supplier	Model
10	10.3×10.3×4.0	FENG-JUI	TPRH10D40-10R
10	10.1×10.1×3.0	Sumida	CDRH104R
15	10.3×10.3×4.0	FENG-JUI	TPRH10D40-15R

Output Capacitor Selection

The output capacitor is required to maintain the DC output voltage. Low ESR capacitors are preferred to keep the output voltage ripple low. In a buck converter circuit, output ripple voltage is determined by inductor value, switching frequency, output capacitor value and ESR. The output ripple is determined by:

$$\Delta V_O = \Delta I_L \times \left(\text{ESR}_{C_{OUT}} + \frac{1}{8 \times f \times C_{OUT}} \right)$$

Where f = operating frequency, C_{OUT} = output capacitance and ΔI_L = ripple current in the inductor. For a fixed output voltage, the output ripple is highest at maximum input voltage since ΔI_L increases with input voltage.

Using Ceramic Input and Output Capacitors

Care must be taken when ceramic capacitors are used at the input and the output. When a ceramic capacitor is used at the input and the power is supplied by a wall adapter through long wires, a load step at the output can induce ringing at the input, V_{IN} . In best condition, this ringing can couple to the output and be mistaken as loop instability. In worst condition, a sudden inrush of current through the long wires can potentially generate a voltage spike at V_{IN} , which may large enough to damage the part. When choosing the input and output ceramic capacitors, choose the one with X5R or X7R dielectric formulations. These dielectrics have the best temperature and voltage characteristics of all the ceramics for a given value and size.

PC Board Layout Checklist

1. The power traces, consisting of the GND, SW and V_{IN} traces, should be kept short, direct and wide.
2. Place C_{IN} near V_{CC} pin as closely as possible to maintain input voltage steady and filter out the pulsing input current.

This datasheet contains new product information. Feeling Technology reserves the rights to modify the product specification without notice. No liability is assumed as a result of the use of this product. No rights under any patent accompany the sales of the product.

3. The resistive divider R_1 and R_2 must be connected to FB pin directly and as closely as possible.
4. FB is a sensitive node. Please keep it away from switching node SW. A good approach is to route the feedback trace on another layer and have a ground plane between the top and feedback trace routing layer. This reduces EMI radiation on to the DC-DC converter's own voltage feedback trace.
5. Keep the GND plates of C_{IN} and C_{OUT} as close as possible. Then connect this to the ground plane (if one is used) with several vias. This reduces ground plane noise by preventing the switching currents from circulating through the ground plane. It also reduces ground bounce at the FP6111 GND pin by giving it a low impedance ground connection.

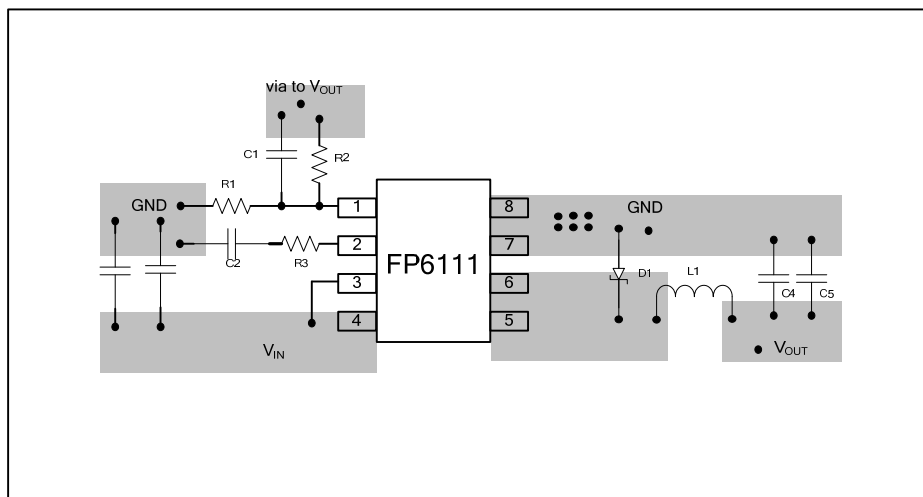

Suggested Layout

Typical Application

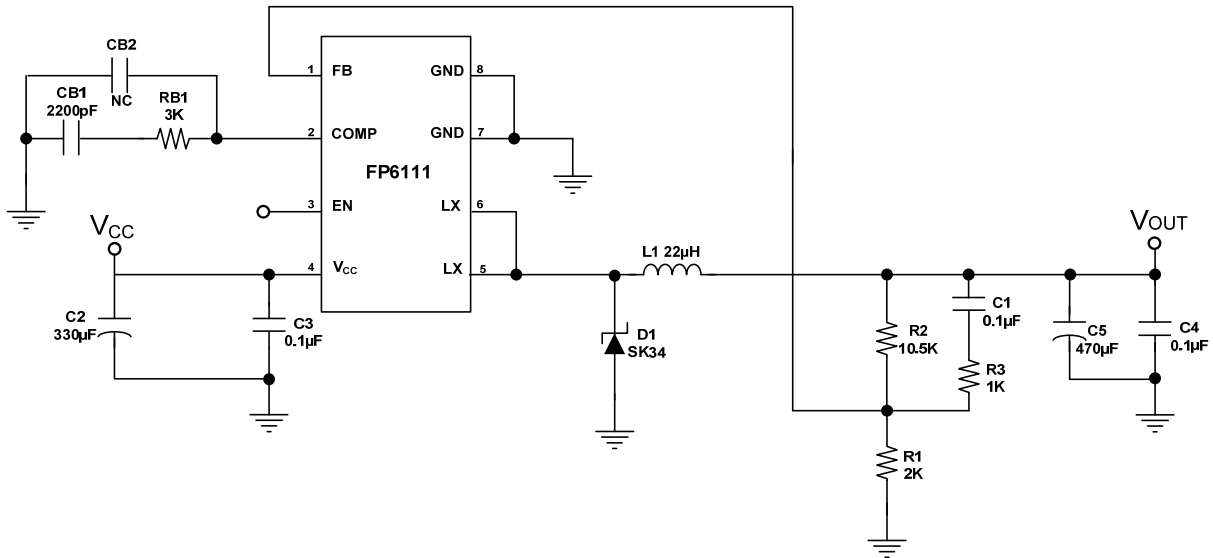

FP6111 Basic DC-DC Regulator Circuit

For example:

The V_{IN} power supply is 12V and the V_{OUT} is designed for 5.0V / 2A solution.

The output voltage formula is:

$$V_{OUT} = \left(1 + \frac{R_2}{R_1}\right) \times V_{REF} = \left(1 + \frac{10.5K\Omega}{2K\Omega}\right) \times 0.8V = 5.0V$$

Package Outline

SOP-8L

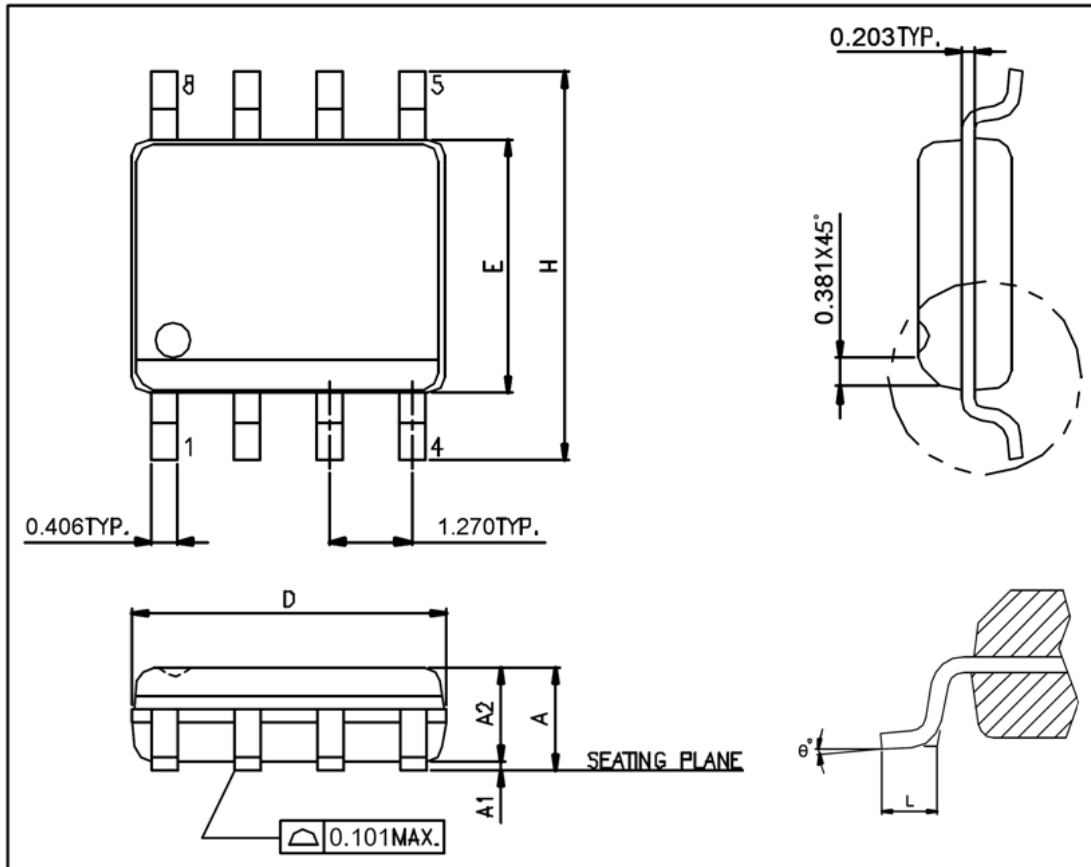

Symbols	Min. (mm)	Max. (mm)
A	1.346	1.752
A1	0.101	0.254
A2	1.092	1.498
D	4.800	4.978
E	3.810	3.987
H	5.791	6.197
L	0.406	1.270
θ°	0°	8°

Note:

1. Package dimensions are in compliance with JEDEC Outline: MS-012 AA.
2. Dimension "D" does not include molding flash, protrusions or gate burrs.
3. Dimension "E" does not include inter-lead flash, or protrusions.

This datasheet contains new product information. Feeling Technology reserves the rights to modify the product specification without notice. No liability is assumed as a result of the use of this product. No rights under any patent accompany the sales of the product.